

TALBOT PARK BAPTIST CHURCH, TRS.
 6919 GRANBY ST
 NORFOLK, VA 23505-4446
 363FT & REAR PARCELS

Neighborhood Number
 131490

TAXING DISTRICT INFORMATION
 Jurisdiction Name NORFOLK
 Area 001 Norfolk
 District 002 Sale Ratio District
 Section & Plat 0846B
 Routing Number 1439263540

Transfer of Ownership

Owner	Consideration	Transfer Date	Deed Book/Page	Deed Type
	0	11/11/1911	9999 9999	

Site Description
 Topography
 Level
 Public Utilities
 Water, Sewer, Gas, Electric
 Street or Road
 Paved, Sidewalk
 Neighborhood
 Improving
 Zoning:
 IN Institutional
 Legal Acres:
 2.0834

Valuation Record

Assessment Year	2013	2014	2015	2016	2017	2018	2019	
Reason for Change	Reassess	Reassess	Reassess	Reassess	Reassess	Reassess	Reassess	
0	L 1089000	1089000	1270500	1270500	1270500	1270500	1270500	
	I 2953700	2645200	2636300	2636300	3181500	3181500	3320400	
	T 4042700	3734200	3906800	3906800	4452000	4452000	4590900	



Land Size

Land Type	Rating, Soil ID - or - Actual Frontage	Acreage - or - Effective Frontage	Square Feet - or - Effective Depth	Influence Factor
Primary Commercial/Indust Land			90750.00	

Physical Characteristics

ROOFING

Built-up

WALLS

	B	1	2	U
Brick	Yes	Yes	Yes	Yes
Guard	Yes	Yes	Yes	Yes

FRAMING

	B	1	2	U
F Res	0	35944	29940	9177

FINISH

	UF	SF	FO	FD
1	35944	0	0	0
2	0	0	0	29940
U	0	0	0	9177
Total	35944	0	0	39117

HEATING AND AIR CONDITIONING

	B	1	2	U
Heat	0	35944	29940	9177

PLUMBING Residential Commercial

	#	TF	#	TF
Full Baths				
Half Baths			23	46
Extra Fixtures				11
TOTAL	0			57

03

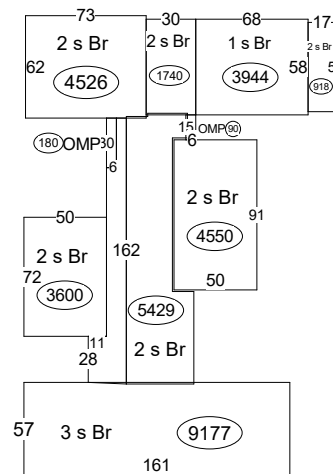

Special Features

Description

Summary of Improvements

ID	USE	Story Height	Const Type	Grade	Year Cons	Eff Year	Cond	Size or Area
C	CHURCH	0.00		Avg	1959	1972	AV	75061
01	OMP	0.00		Avg	1954	1954	AV	0
02	OMP	0.00		Avg	1954	1954	AV	0
03	PAVING	0.00	6	Avg	1988	1988	AV	245x104